

---

## Magnum Mobile Lite Generator – MLG15 Specifications

### ENGINE

- Mitsubishi® S4L2-Y461ML - naturally aspirated, diesel engine
  - Prime - 22.3 hp @ 1800 rpm
  - 4 cylinder
  - 1.8 L displacement
  - Interim Tier IV approved
- Polyethylene fuel tank
  - 56 gal. capacity
  - 43 hr. run time – full load
  - 3 ½" fill port
- Fuel consumption at prime:
  - 100% - 1.30 gph (4.92 Lph)
  - 75% - 0.98 gph (3.71 Lph)
  - 50% - 0.65 gph (2.46 Lph)
- Cooling system capable of operating at 120°F ambient
- Rubber vibration dampers isolate engine/generator from frame
- Full flow oil filter, spin on type
- Fuel filter with replaceable element
- Dry type cartridge air filter
- 60 Hz engine/generator

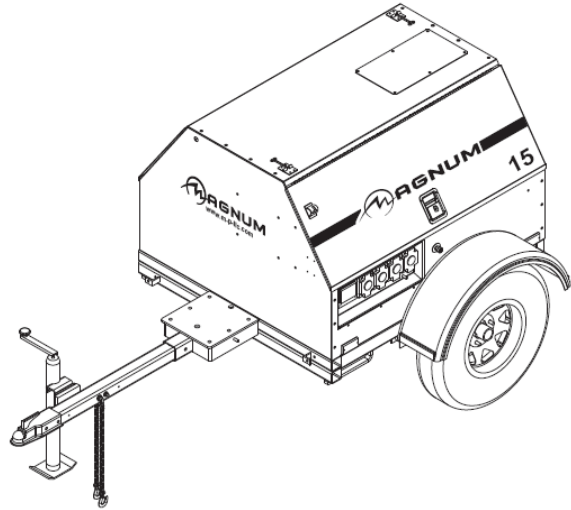

### ENGINE CONTROLS

- Engraved aluminum punched and anodized control panel
- Four position keyed switch – glow plugs (preheat, off, run, start)
- Hour meter
- Automatic low oil/high temperature shutdown system

### GENERATOR

- Marathon Electric®
  - Brushless
  - 4 pole
  - Class H insulation
- Single phase output
  - Prime - 13 kW / 13 kVA (54A @ 240V)
  - Standby - 14 kW / 14 kVA (58A @ 240V)
- Voltage regulation +/- 1% with Marathon SE350 Voltage Regulator

## ELECTRICAL SYSTEM AND CONTROLS

- 70A start limit breaker (assures no load condition exists before starting)
- Convenience receptacles with individual breakers
  - (2) 120V 20 Amp GFCI duplex outlets (Nema 5-20R type)
  - (2) 240V 30 Amp twistlock outlets (Nema L6-30R type)
  - (2) 240V 50 Amp twistlock outlets (Non-Nema 6369)
- 440 CCA wet cell battery

## ENCLOSURE

- Steel, 14-gauge, sound attenuated enclosure
  - UV & fade resistant, high temperature cured, white polyester powder paint
  - Insulated and baffled
  - 70 dB(A) at 23 feet – prime power
- Fully lockable enclosure
- Stainless steel hinges, door latches and exterior hardware
- Emergency stop switch located on front panel
- License plate holder with light
- Multi-lingual operating/safety decals
- Document holder with operating/parts manuals including AC/DC wiring diagrams

## TRAILER

- DOT approved tail, side, brake, and directional lights
  - Recessed rear lights
- Transportation tie downs
- Safety chains with spring loaded safety hooks
- Single wall polyethylene fenders
- 2" ball hitch
- 2200 lb. leaf spring axle
- 2000 lb. tongue jack with footplate
- ST205/75R15 tubeless tires – 6 ply
- 48" track width

## WEIGHTS & DIMENSIONS

- Dry weight: 1425 lbs (646 kg)
- Operating weight: 1823 lbs (827 kg)
- 105 x 68 x 56 in  
(2.67 x 1.73 x 1.42 m)

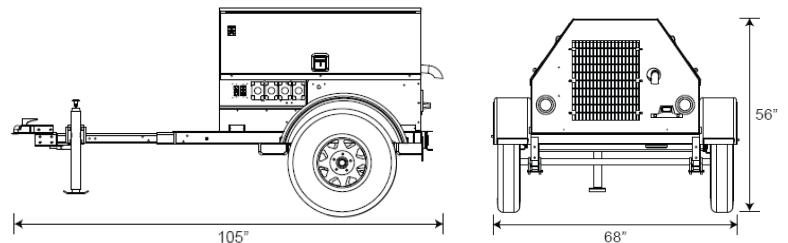

## WARRANTY

- Engine and generator covered under OEM warranty – consult factory for details

## CERTIFICATIONS

- CSA certified



## MLG15 Options

### ENGINE OPTIONS

- ◆ Heated fuel filter
- ◆ Lower radiator hose – engine heater
- ◆ Oil drain valve kit

### ELECTRICAL CONTROLS OPTIONS

- ◆ 720 CCA gel cell battery
- ◆ 720 CCA wet cell battery
- ◆ 685 CCA gel cell battery
- ◆ Battery disconnect
- ◆ Battery charger – 2A trickle

### VOLTAGE OUTPUT OPTIONS

- ◆ Alternative receptacle panel – consult factory for configurations

### COOLANT OPTIONS

- ◆ 60/40 Coolant – cold weather applications

### ENCLOSURE OPTIONS

- ◆ Interior cabinet light
- ◆ Level indicator
- ◆ Tamper pack
- ◆ Liquid containment / Quiet pack
- ◆ Lift structure

### FUEL TANK OPTIONS

- ◆ 56 gal. fuel tank
- ◆ Tethered fuel tank cap

### TRAILER OPTIONS

- ◆ 6 pin or 7 spade electrical connectors
- ◆ Outrigger package
- ◆ Tube and sleeve jack
- ◆ Spare tire/wheel kit

### HITCH OPTIONS

- ◆ 2.5” lunette ring
- ◆ 3” lunette ring
- ◆ 3” HD lunette ring
- ◆ 2 5/16” ball
- ◆ Combination hitch – 2.5” lunette ring / 2” ball

